



Convergent Service Delivery Platforms and Service Orchestration



Covergence Media&Networks
Alf H. Wulf
April 2007

Agenda

1. Understanding Triple Play Demand
2. Challenges to Triple Play Delivery
3. Turning Challenges into Opportunities
4. Your Partner for Transformation

1

Understanding Triple Play Demand

Shifts in User Expectation for Triple Play and Competitive Environments

Demand Drivers for Services

Personalization

“Primetime” shifts to “My Time”

Consumers become producers

Device proliferation breeds fragmentation

Interactivity

Permission marketing invades television

Voice, video and data finally collide

Can you “see” me now?

Accessibility

Placeshifting becomes commonplace

Mobile phone becomes remote control

Managing “Always on” without being always accessible

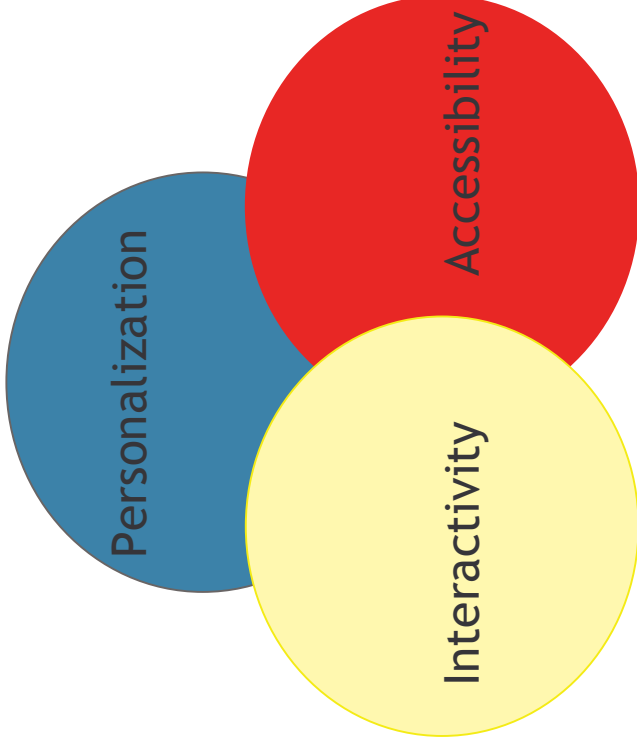

Source: Alcatel Focus Group Research

The Emerging Market Opportunity: From Diversity to Convergence

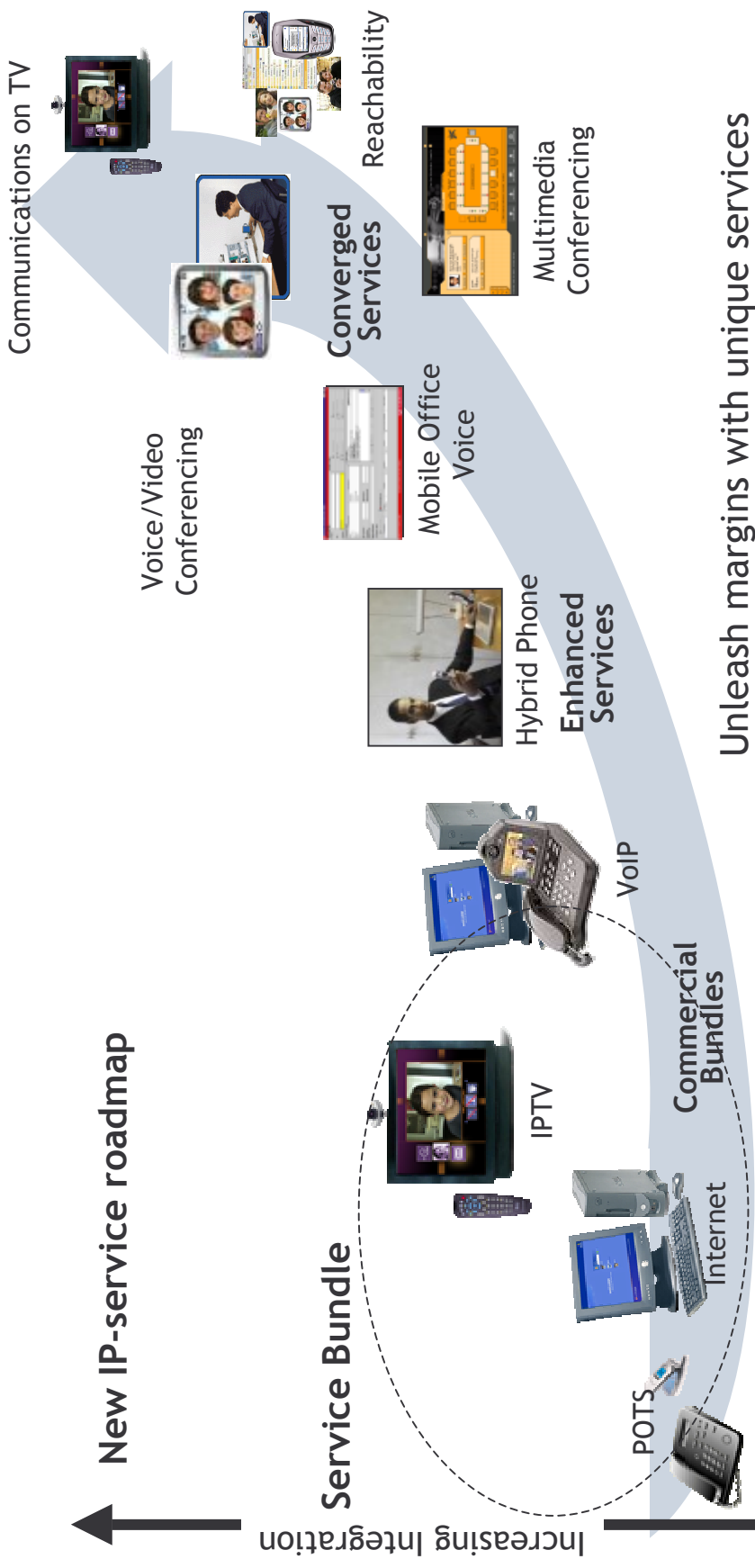

	Com	Slovakia		US		United Kingdom		France
	IMS-ready Class 5		Triple Play bundle	Residential and enterprise VoIP			Reachability pilot	

Leverage the Excitement and Diversity Drive



Rich multimedia

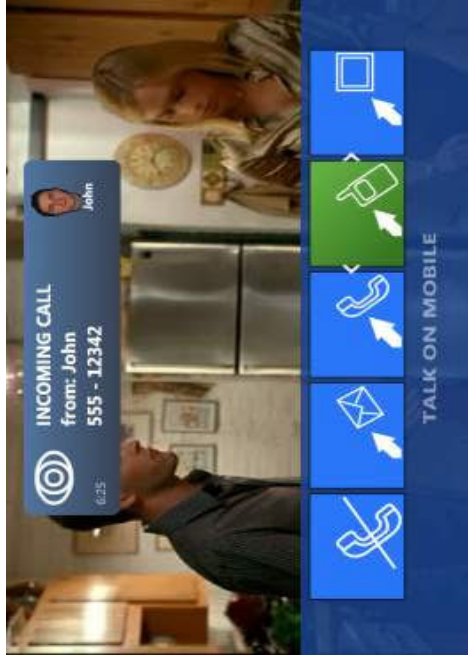

TV as Part of communication mix

Extend communication to TV
Richer telephony on the TV screen
Keep watching your TV program

Mobile Instant Messaging

Extend PC IM to mobile handsets
Richer communication beyond voice
Always reachable by your buddies



Wider reach

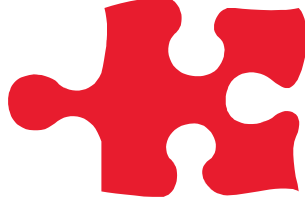

Leverage the Comfort and Simplicity Drive



Subscriber control

- More than a mobile
- Great value
- Wireless living
- In-office mobile coverage
- Easy set-up



Take a closer look

One phone, one number, one bill
Increase productivity and reachability
Cost-optimized routing
Same environment wherever you are e.g. PBX

Guaranteed QoS Multi-Service Delivery

Video voice and data policy management
Smooth combined service delivery e.g. conversation on TV
Smooth multi-terminal service delivery e.g. dad's and son's simultaneous access

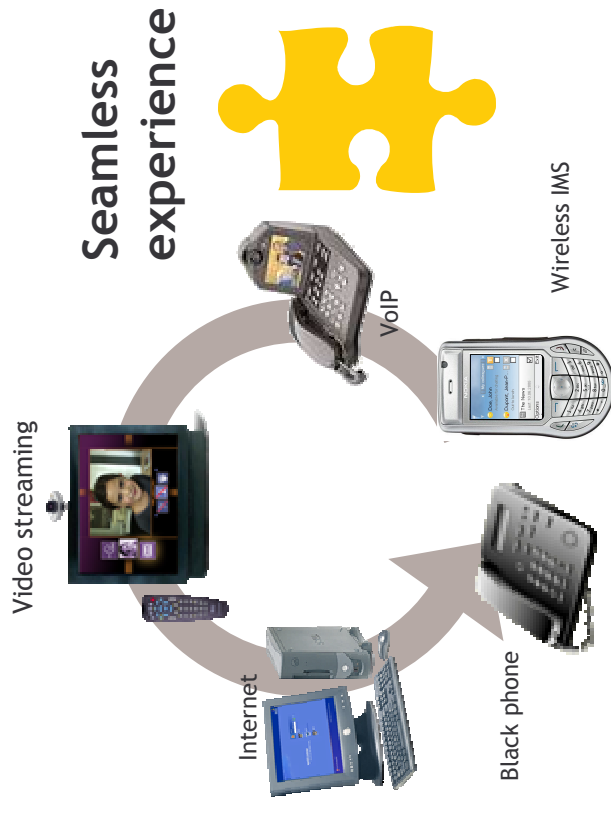

2

Challenges to Triple Play Delivery

Network and Service Delivery Requires Best-In-Class Networking, Rapid Service Creation and Easy Integration

Network Expectations Need to Be Met

Example: How a Gamer Judges a Connection

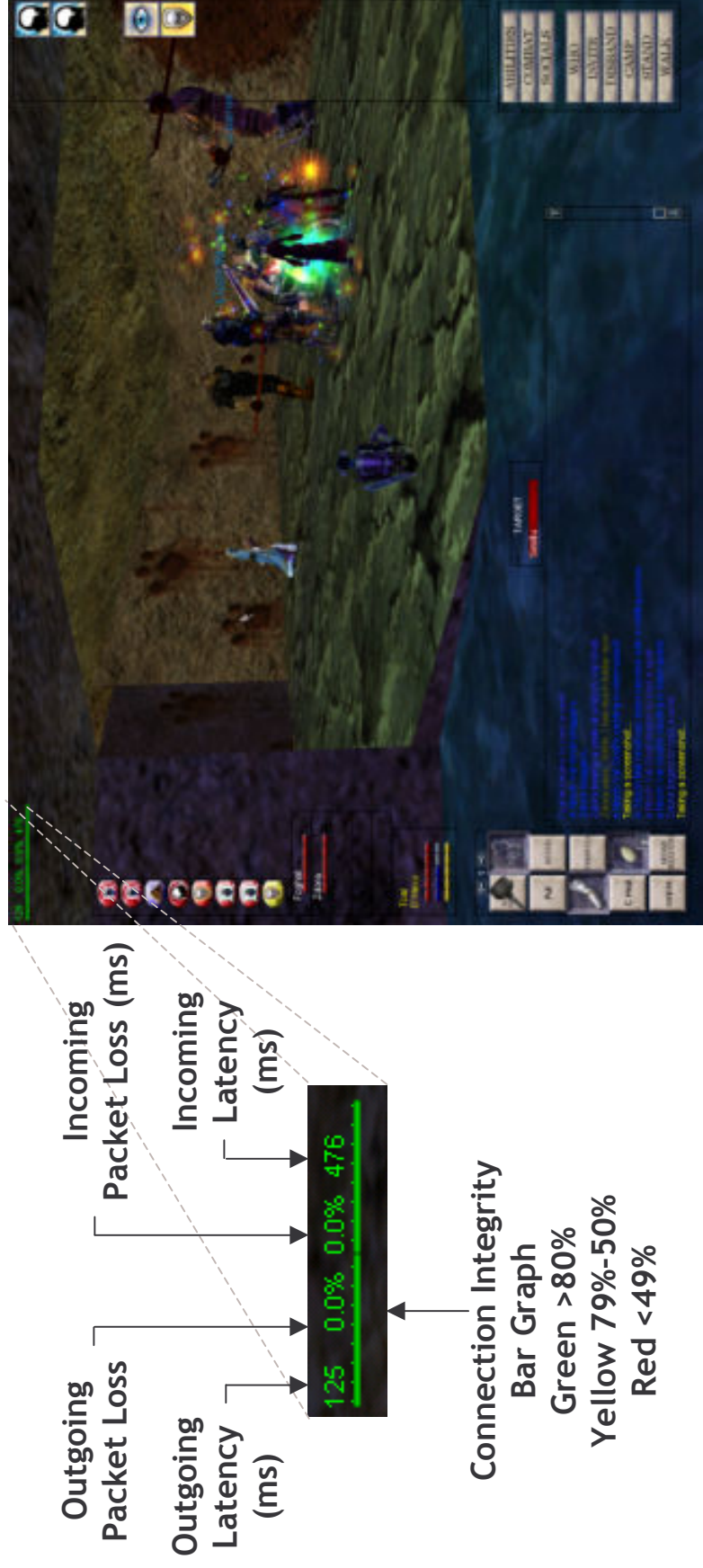

Source: Screen shot from Sony Online Entertainment's EverQuest MMORPG

Even for high-speed Internet, the end users' network expectations are becoming increasingly high

The New Competitive Opportunity: Service Creation, Control and Integration

Combined service providers need to leverage **service creation and control** to optimize innovation and quickly deliver value-added services, smoothly migrated via **service integration**

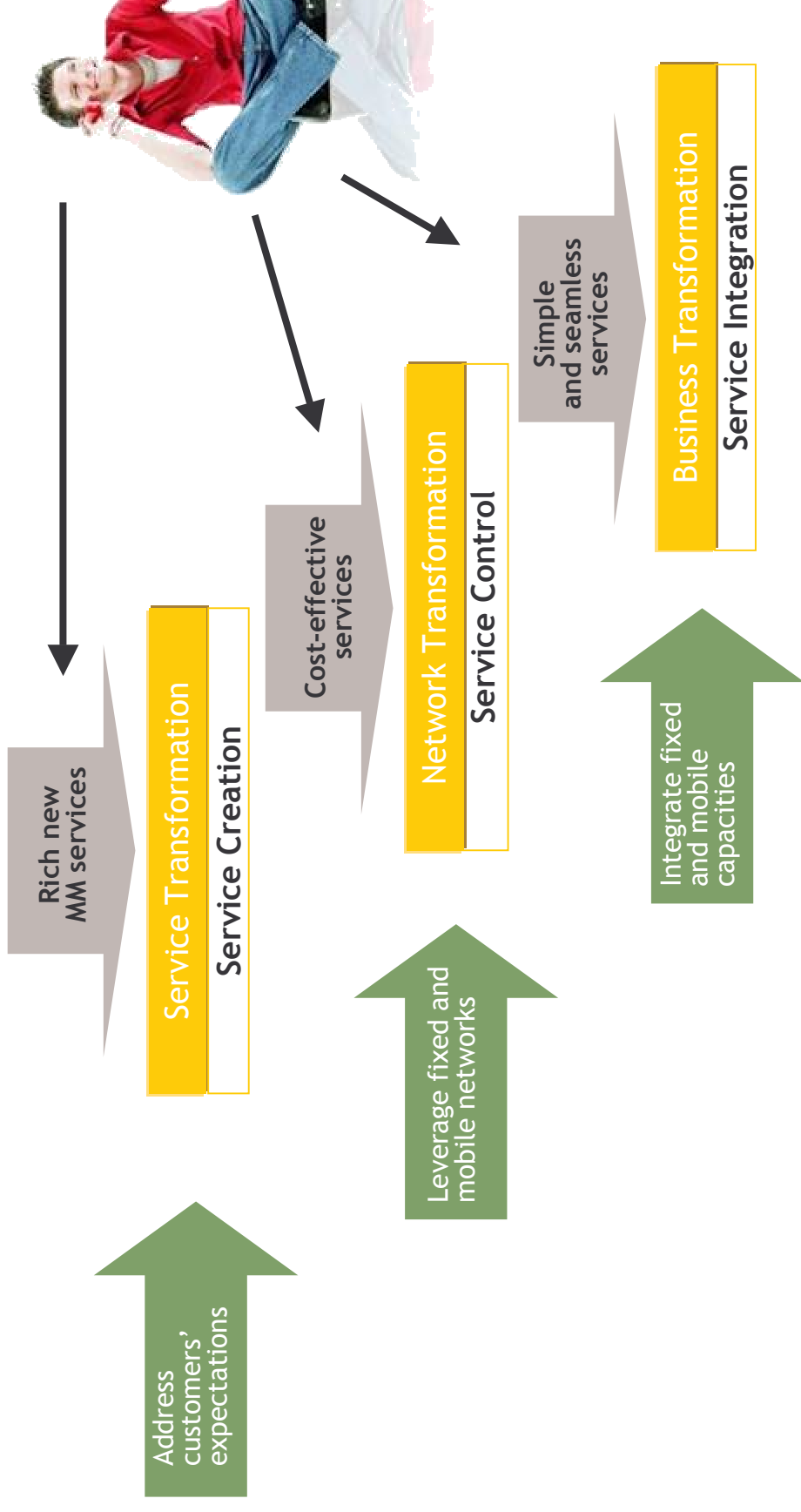

3

Turning Challenges into Opportunities

Transform to a Triple Play Architecture Delivering
Next Generation Blended Services... Today

Attributes of a Successful Network Transformation

End-to-End IP Quality of Service

Utilization of Flexible Platforms that Address Changing Needs

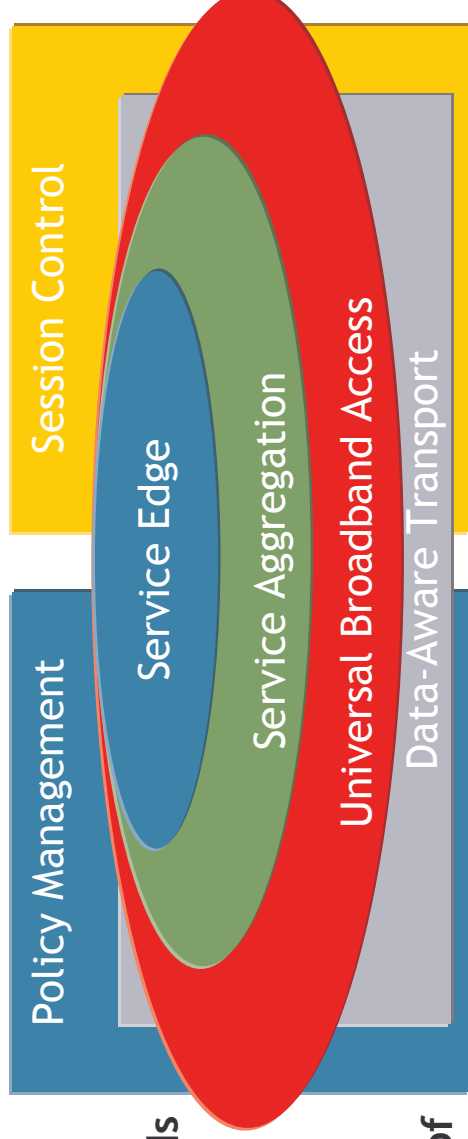

Optimization of Last Mile and Spectrum Usage

Resilient, Non-Stop IP Infrastructure

Unified, Policy-Rich Network for All Services

Managed Bandwidth Scaling over Any Medium

Cost reduction and simplification speeds time-to-market for new bandwidth consuming services

Network Transformation

Industry-Proven End-to-End Design

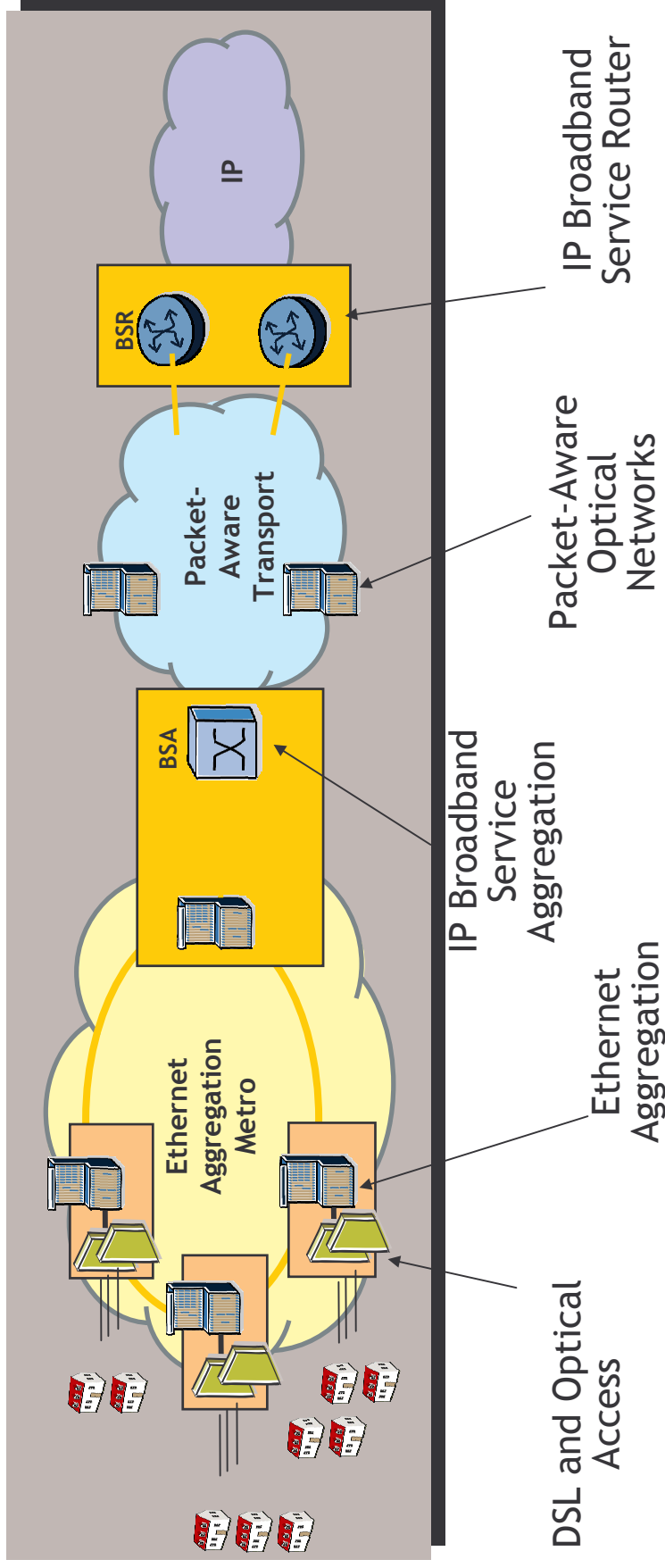

Built from the ground up for services demanding scalable QoS
 industry-proven Triple Play Service Delivery Architecture (TPSDA)

Alcatel-Lucent Acuity Transformation Framework

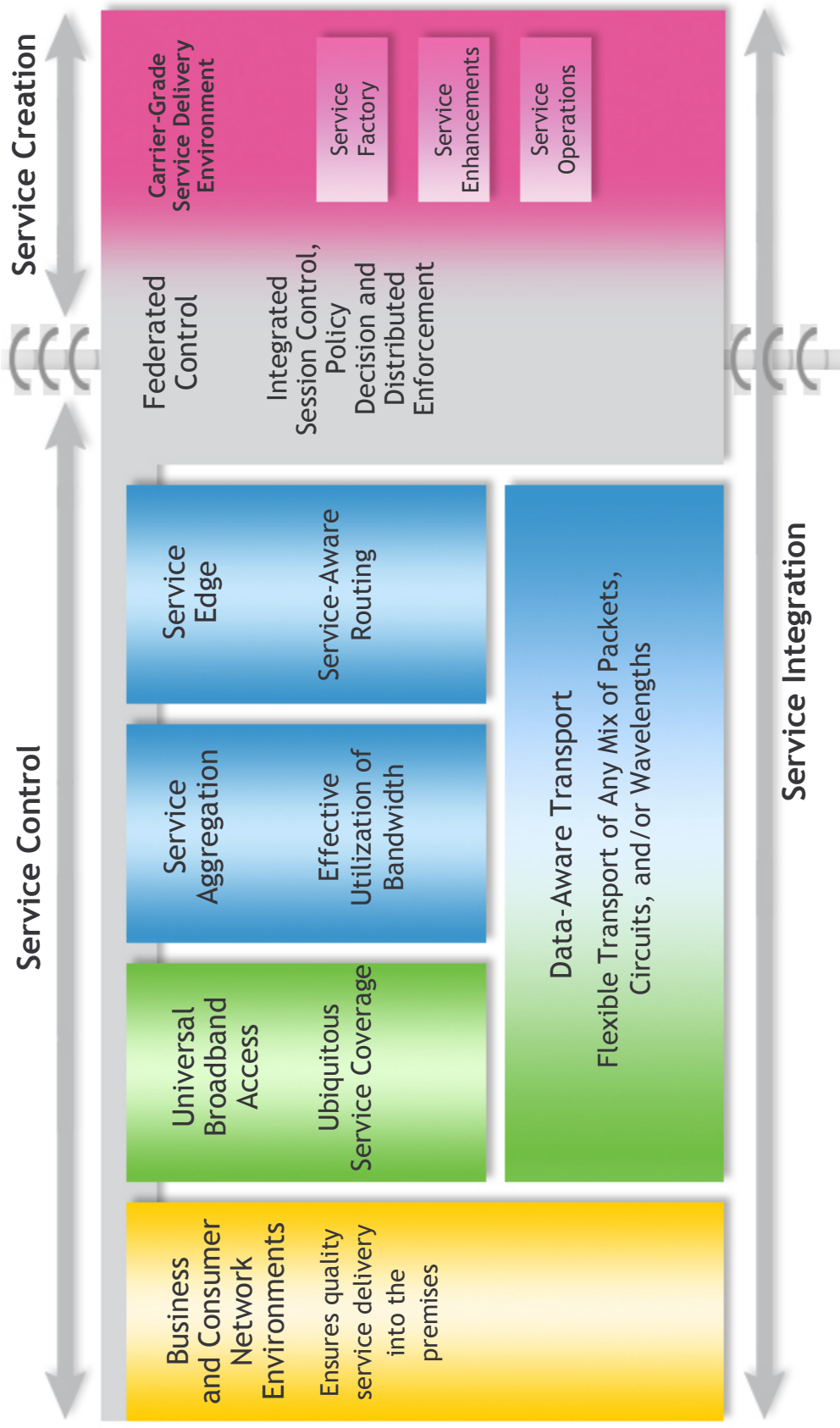

Linking service creation to service control provides an end-to-end Quality of Experience

Alcatel-Lucent NGN Services for Consumers: Solutions

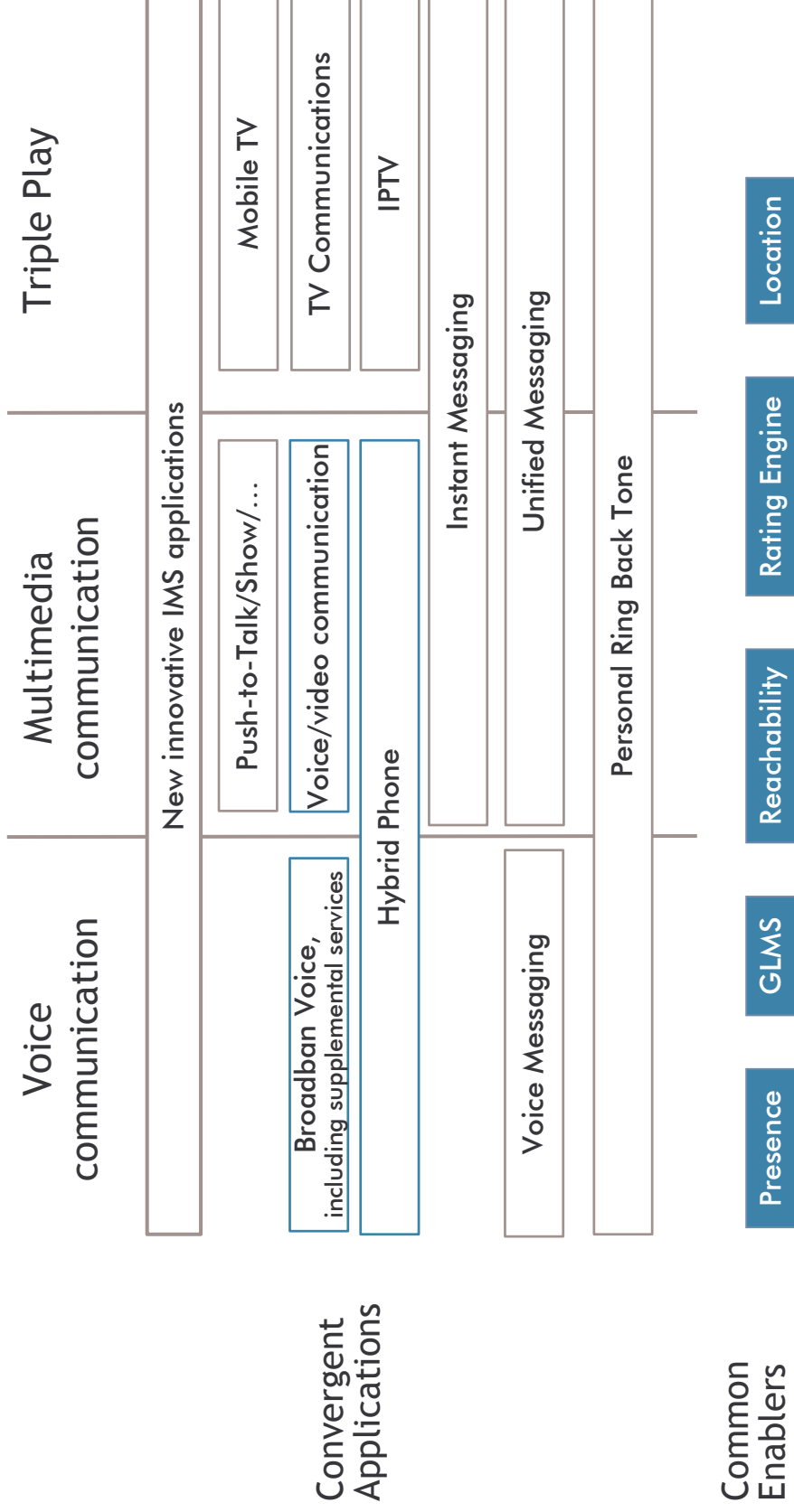

In Summary

- Proven real customer request for “Triple Play”
- Challenge configuring and building the network
- Opening multiple opportunities to generate revenue
- Orchestra of components must be concerted



www.alcatel-lucent.com